

FAR CALCULATION (SQ.M.)

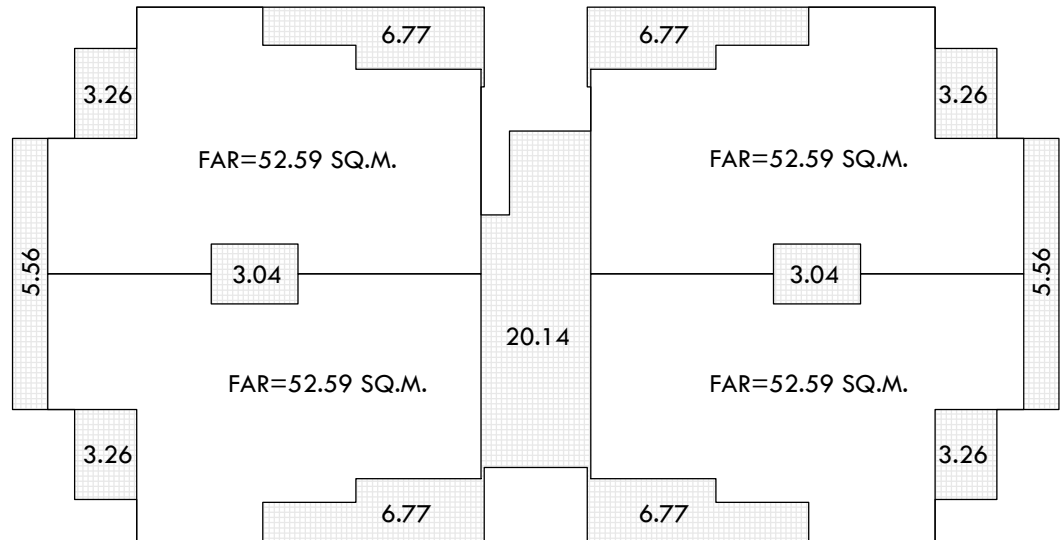

UP.GR, 1ST & 2ND FLOOR PLAN
FAR=210.36 SQ.M.

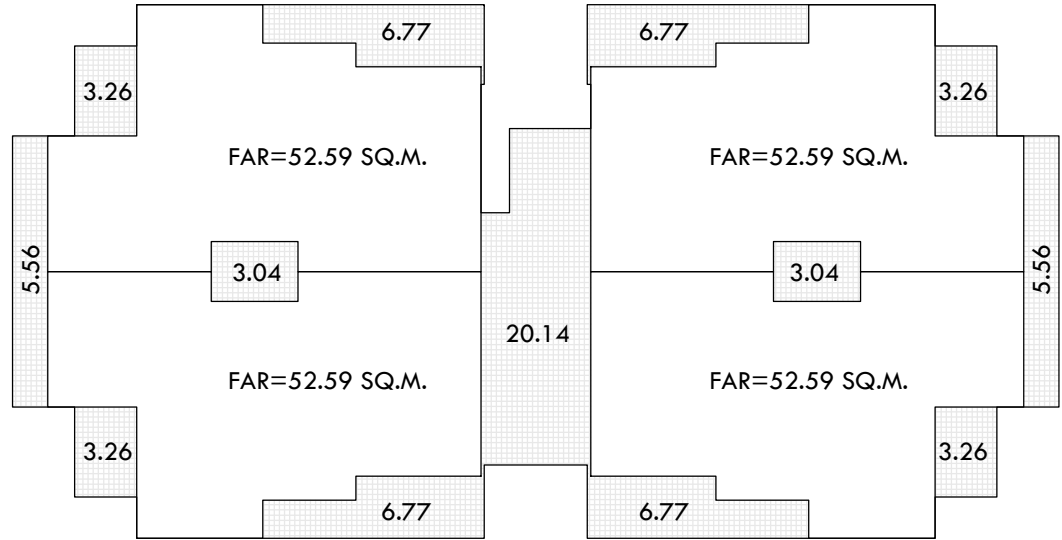

3RD FLOOR PLAN
FAR=210.36 SQ.M.

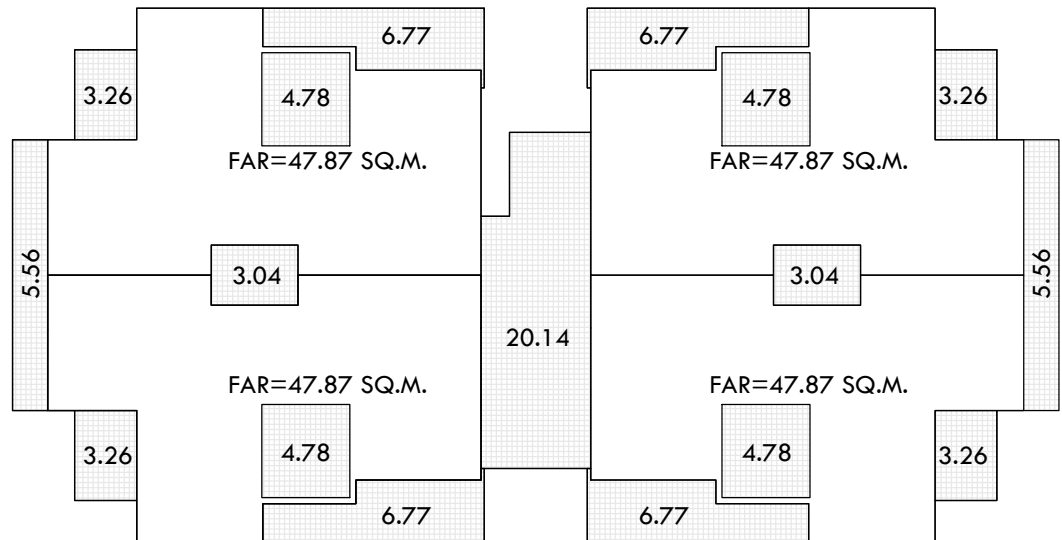

4TH FLOOR PLAN
FAR=191.48 SQ.M.

SALE CALCULATION (SQ.M.)

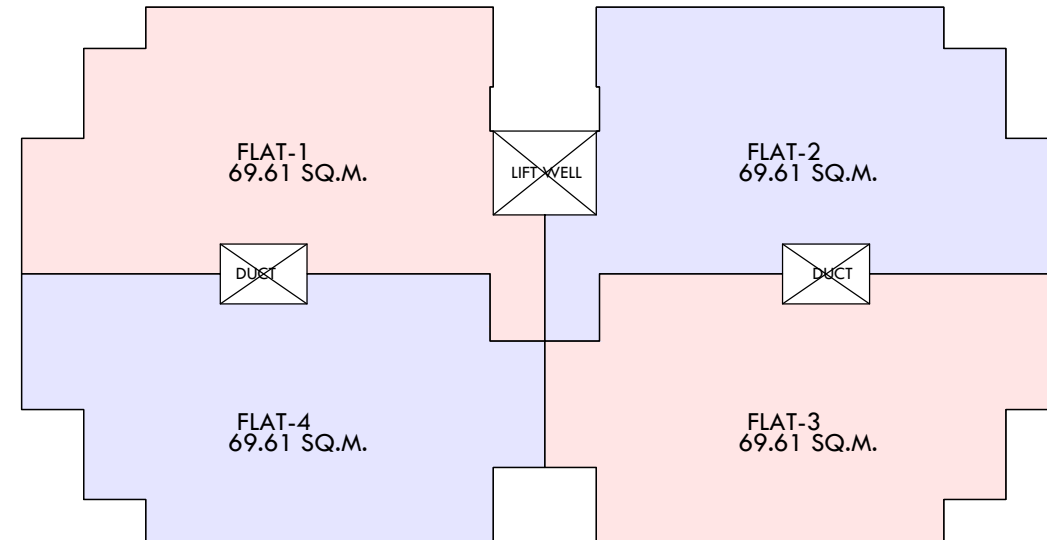

UP.GR, 1ST & 2ND FLOOR PLAN
SALE=278.44 SQ.M.

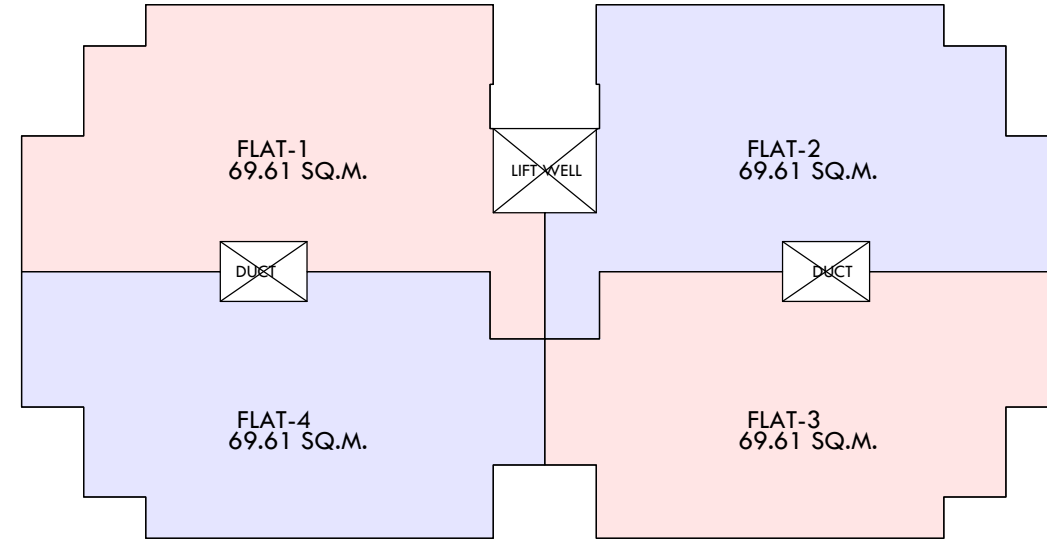

3RD FLOOR PLAN
FAR=278.44 SQ.M.

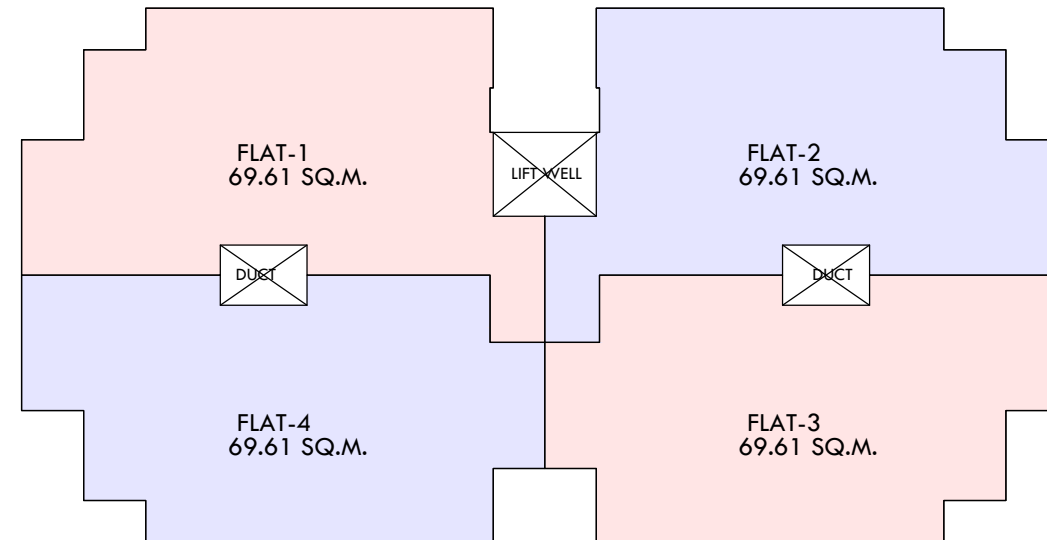

4TH FLOOR PLAN
FAR=278.44 SQ.M.

PERFORMA -A

FAR CALCULATION

FLR.	USE	TOTAL BUA	AREA FREE FROM FAR				NET BUA	FAR
			BAL.	ST.C	DUCT	TOTAL		
A		B	C				B-C	D
STILT	PARK	243.07						
U.GR.	RESI.	287.87	51.24	20.14	6.08	77.46	210.41	20%
1ST	RESI.	287.87	51.24	20.14	6.08	77.46	210.41	20%
2ND	RESI.	287.87	51.24	20.14	6.08	77.46	210.41	20%
3RD	RESI.	287.87	51.24	20.14	6.08	77.46	210.41	20%
4TH	RESI.	287.87	51.24	39.26	6.08	96.58	191.29	20%
TOTAL		1682.42	256.20	139.96	30.40	406.42	1032.93	100%

CONTENT OF SHEET

FAR & SALE CALCULATION

NAME OF OWNER

MR.VISHNU FROM GOA

NAME OF LICENSEE :

NAME AND SIGNATURE OF ARCHITECT

LICENCE.NO. : CA/2005/35347



UDAY KANADIA-9819885131

409,HIGHWAY COMMERCIAL TOWER,I.B.PATEL ROAD
LAGHU UDHYOG,GOREGOAN (E),MUMBAI- 63

TEL : 022-06860356 EMAIL : udaykanadia@gmail.com

NORTH	SCALE	DATE
	F.T.S	30.07.18
	DRAWN BY :	CHECKED BY :
	SWATI	UDAY

DRAWING NO. 1 REVISION NO.